

# LM431

## Adjustable Precision Zener Shunt Regulator

### General Description

The LM431 is a 3-terminal adjustable shunt regulator with guaranteed temperature stability over the entire temperature range of operation. It is now available in a chip sized package (4-Bump micro SMD) using National's micro SMD package technology. The output voltage may be set at any level greater than 2.5V ( $V_{REF}$ ) up to 36V merely by selecting two external resistors that act as a voltage divided network. Due to the sharp turn-on characteristics this device is an excellent replacement for many zener diode applications.

### Features

- Average temperature coefficient 50 ppm/°C
- Temperature compensated for operation over the full temperature range
- Programmable output voltage
- Fast turn-on response
- Low output noise
- LM431 in micro SMD package

### Connection Diagrams

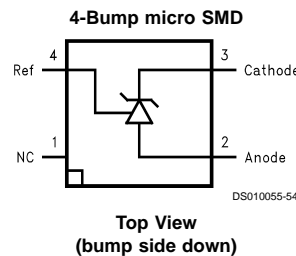
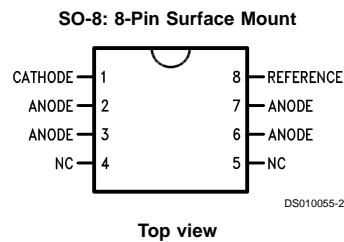
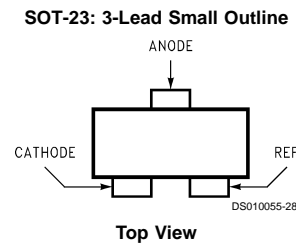
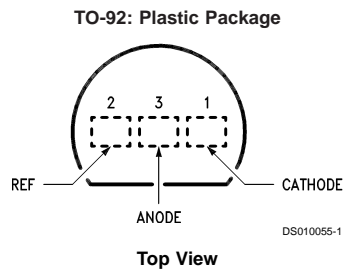

## Ordering Information

Package	Typical Accuracy Order Number/Package Marking			Temperature Range	Transport Media	NSC Drawing
	0.5%	1%	2%			
TO-92	LM431CCZ/ LM431CCZ	LM431BCZ/ LM431BCZ	LM431ACZ/ LM431ACZ	0°C to +70°C	Rails	Z03A
	LM431CIZ/ LM431CIZ	LM431BIZ/ LM431BIZ	LM431AIZ/ LM431AIZ	-40°C to +85°C		
SO-8	LM431CCM/ 431CCM	LM431BCM/ 431BCM	LM431ACM/ LM431ACM	0°C to +70°C	Rails and Tape & Reel	M08A
	LM431CIM/ 431CIM	LM431BIM/ 431BIM	LM431AIM/ LM431AIM	-40°C to +85°C		
SOT-23	LM431CCM3/ N1B	LM431BCM3/ N1D	LM431ACM3/ N1F	0°C to +70°C	Rails and Tape & Reel	MA03B
	LM431CIM3 N1A	LM431BIM3 N1C	LM431AIM3 N1E	-40°C to +85°C		
micro SMD	-	-	LM431AIBP LM431AIBPX(Note 1)	-40°C to +85°C	250 Units Tape and Reel 3k Units Tape and Reel	BPA04AFA

**Note 1:** The micro SMD package marking is a 2 digit manufacturing Date Code only

### micro SMD Top View Marking Example

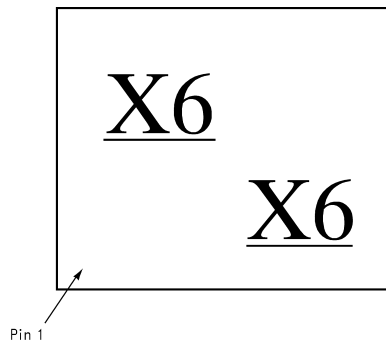

DS010055-56

The LM431 micro SMD Package will be marked with a two digit date manufacturing code. The underline indicates the bottom of the marking. Pin one will be placed at the bottom left hand corner, and the rest of the pin numbers will follow counter-clockwise.

Symbol and Functional Diagrams

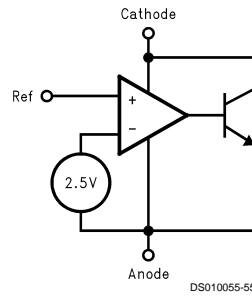
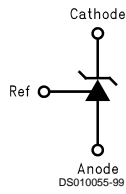

DC Test Circuits

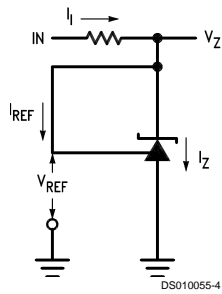
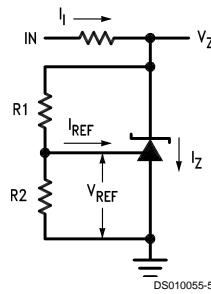

FIGURE 1. Test Circuit for  $V_Z = V_{REF}$



Note:  $V_Z = V_{REF} (1 + R1/R2) + I_{REF} \cdot R1$

FIGURE 2. Test Circuit for  $V_Z > V_{REF}$

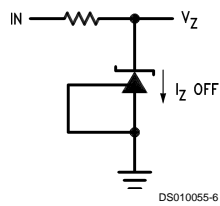

FIGURE 3. Test Circuit for Off-State Current

**Absolute Maximum Ratings** (Note 2)

If Military/Aerospace specified devices are required, please contact the National Semiconductor Sales Office/Distributors for availability and specifications.

Storage Temperature Range	-65°C to +150°C
Operating Temperature Range	
Industrial (LM431xI)	-40°C to +85°C
Commercial (LM431xC)	0°C to +70°C
Soldering Information	
Infrared or Convection (20 sec.)	235°C
Wave Soldering (10 sec.)	260°C (lead temp.)
Cathode Voltage	37V
Continuous Cathode Current	-10 mA to +150 mA

Reference Voltage	-0.5V
Reference Input Current	10 mA
Internal Power Dissipation (Notes 3, 4)	
TO-92 Package	0.78W
SO-8 Package	0.81W
SOT-23 Package	0.28W
micro SMD Package	0.30W

**Operating Conditions**

	<b>Min</b>	<b>Max</b>
Cathode Voltage	$V_{REF}$	37V
Cathode Current	1.0 mA	100 mA

**LM431 Electrical Characteristics**

$T_A = 25^\circ\text{C}$  unless otherwise specified

Symbol	Parameter	Conditions	Min	Typ	Max	Units
$V_{REF}$	Reference Voltage	$V_Z = V_{REF}$ , $I_I = 10\text{ mA}$ LM431A (Figure 1)	2.440	2.495	2.550	V
		$V_Z = V_{REF}$ , $I_I = 10\text{ mA}$ LM431B (Figure 1)	2.470	2.495	2.520	V
		$V_Z = V_{REF}$ , $I_I = 10\text{ mA}$ LM431C (Figure 1)	2.485	2.500	2.510	V
$V_{DEV}$	Deviation of Reference Input Voltage Over Temperature (Note 5)	$V_Z = V_{REF}$ , $I_I = 10\text{ mA}$ , $T_A = \text{Full Range}$ (Figure 1)		8.0	17	mV
$\frac{\Delta V_{REF}}{\Delta V_Z}$	Ratio of the Change in Reference Voltage to the Change in Cathode Voltage	$I_Z = 10\text{ mA}$ , $V_Z$ from $V_{REF}$ to 10V (Figure 2)		-1.4	-2.7	mV/V
		$V_Z$ from 10V to 36V		-1.0	-2.0	
$I_{REF}$	Reference Input Current	$R_1 = 10\text{ k}\Omega$ , $R_2 = \infty$ , $I_I = 10\text{ mA}$ (Figure 2)		2.0	4.0	$\mu\text{A}$
$\alpha I_{REF}$	Deviation of Reference Input Current over Temperature	$R_1 = 10\text{ k}\Omega$ , $R_2 = \infty$ , $I_I = 10\text{ mA}$ , $T_A = \text{Full Range}$ (Figure 2)		0.4	1.2	$\mu\text{A}$
$I_{Z(MIN)}$	Minimum Cathode Current for Regulation	$V_Z = V_{REF}$ (Figure 1)		0.4	1.0	mA
$I_{Z(OFF)}$	Off-State Current	$V_Z = 36\text{V}$ , $V_{REF} = 0\text{V}$ (Figure 3)		0.3	1.0	$\mu\text{A}$
$f_Z$	Dynamic Output Impedance (Note 6)	$V_Z = V_{REF}$ , LM431A, Frequency = 0 Hz (Figure 1)			0.75	$\Omega$
		$V_Z = V_{REF}$ , LM431B, LM431C, Frequency = 0 Hz (Figure 1)			0.50	$\Omega$

**Note 2:** Absolute Maximum Ratings indicate limits beyond which damage to the device may occur. Electrical specifications do not apply when operating the device beyond its rated operating conditions.

**Note 3:**  $T_{J\text{ Max}} = 150^\circ\text{C}$ .

**Note 4:** Ratings apply to ambient temperature at 25°C. Above this temperature, derate the TO-92 at 6.2 mW/°C, the SO-8 at 6.5 mW/°C, the SOT-23 at 2.2 mW/°C and the micro SMD at 3mW/°C.

**Note 5:** Deviation of reference input voltage,  $V_{DEV}$ , is defined as the maximum variation of the reference input voltage over the full temperature range.

**LM431**  
**Electrical Characteristics** (Continued)

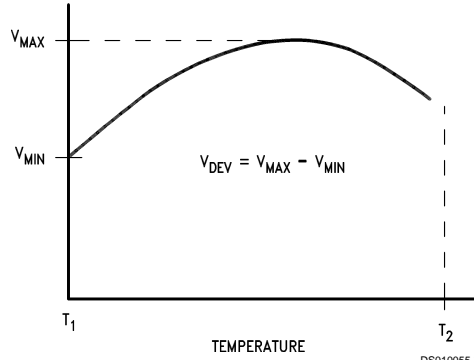

DS010055-7

The average temperature coefficient of the reference input voltage,  $\infty V_{REF}$ , is defined as:

$$\infty V_{REF} \frac{\text{ppm}}{^{\circ}\text{C}} = \frac{\pm \left[ \frac{V_{MAX} - V_{MIN}}{V_{REF}(\text{at } 25^{\circ}\text{C})} \right] 10^6}{T_2 - T_1} = \pm \left[ \frac{V_{DEV}}{V_{REF}(\text{at } 25^{\circ}\text{C})} \right] 10^6$$

Where:

$T_2 - T_1$  = full temperature change (0-70°C).

$\infty V_{REF}$  can be positive or negative depending on whether the slope is positive or negative.

Example:  $V_{DEV} = 8.0 \text{ mV}$ ,  $V_{REF} = 2495 \text{ mV}$ ,  $T_2 - T_1 = 70^{\circ}\text{C}$ , slope is positive.

$$\infty V_{REF} = \frac{\left[ \frac{8.0 \text{ mV}}{2495 \text{ mV}} \right] 10^6}{70^{\circ}\text{C}} = +46 \text{ ppm}/^{\circ}\text{C}$$

**Note 6:** The dynamic output impedance,  $r_z$ , is defined as:

$$r_z = \frac{\Delta V_Z}{\Delta I_Z}$$

When the device is programmed with two external resistors,  $R_1$  and  $R_2$ , (see *Figure 2*), the dynamic output impedance of the overall circuit,  $r_z$ , is defined as:

$$r_z = \frac{\Delta V_Z}{\Delta I_Z} \cong \left[ r_z \left( 1 + \frac{R_1}{R_2} \right) \right]$$

**Equivalent Circuit**

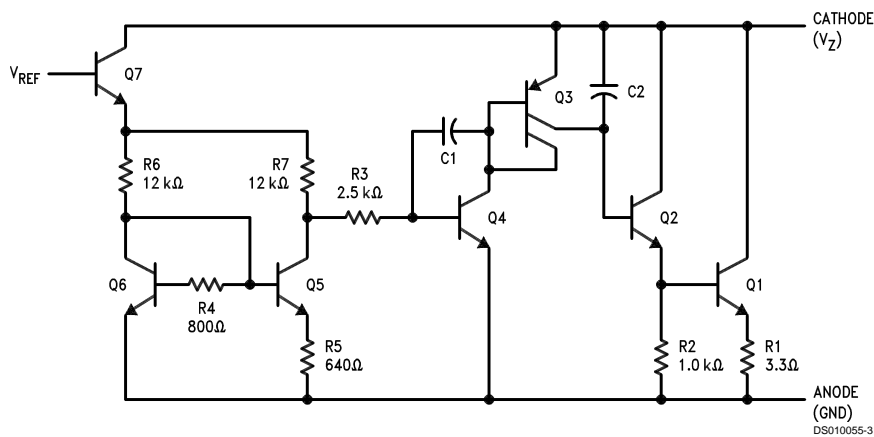

DS010055-3

## Typical Performance Characteristics

Input Current vs  $V_Z$

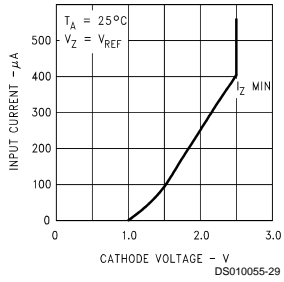

Thermal Information

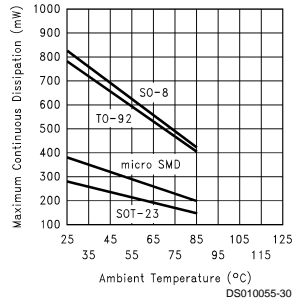

Input Current vs  $V_Z$

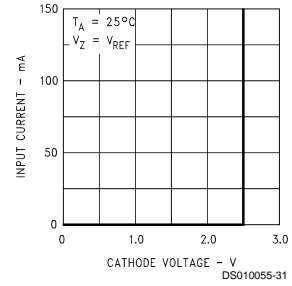

Dynamic Impedance vs Frequency

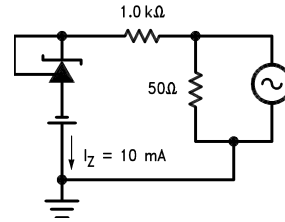
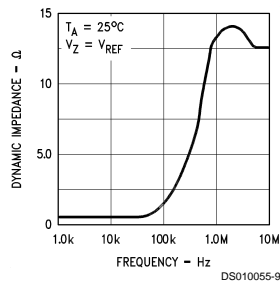

Stability Boundary Conditions

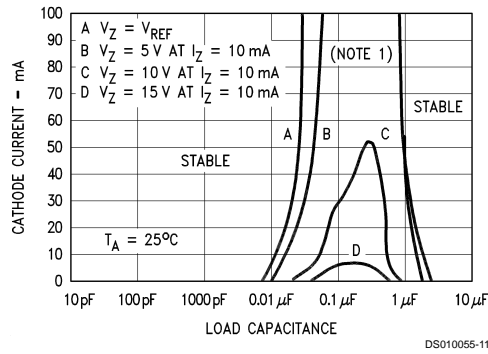

**Note:** The areas under the curves represent conditions that may cause the device to oscillate. For curves B, C, and D,  $R_2$  and  $V^+$  were adjusted to establish the initial  $V_Z$  and  $I_Z$  conditions with  $C_L = 0$ .  $V^+$  and  $C_L$  were then adjusted to determine the ranges of stability.

Test Circuit for Curve A Above

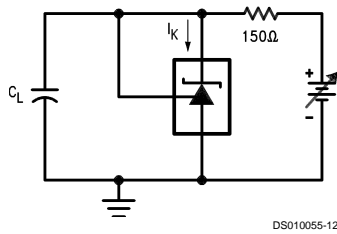

Test Circuit for Curves B, C and D Above

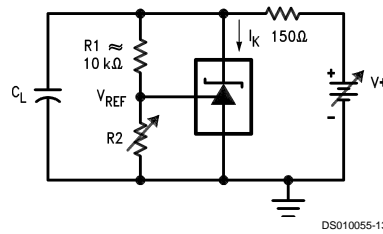

### Typical Applications

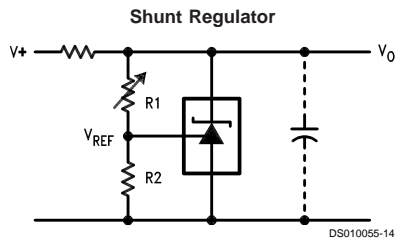

DS010055-14

$$V_O \approx \left(1 + \frac{R_1}{R_2}\right) V_{REF}$$

**Single Supply Comparator with Temperature Compensated Threshold**

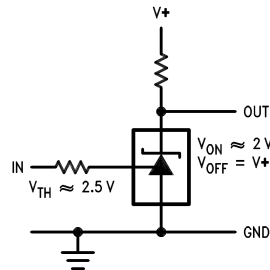

DS010055-15

$V_{ON} \approx 2\text{ V}$   
 $V_{OFF} = V^+$   
 $V_{TH} \approx 2.5\text{ V}$

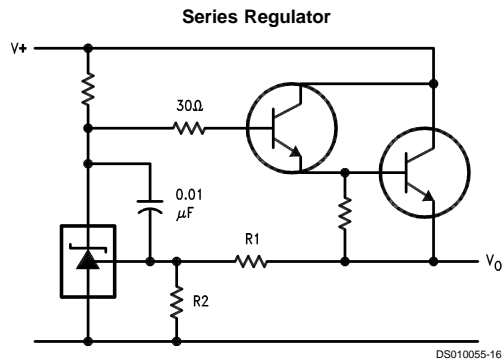

DS010055-16

$$V_O \approx \left(1 + \frac{R_1}{R_2}\right) V_{REF}$$

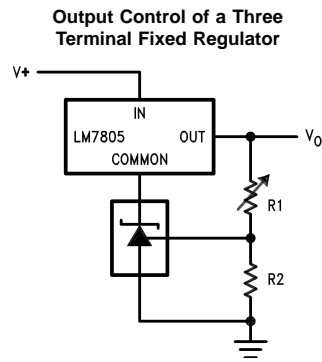

DS010055-17

$$V_O = \left(1 + \frac{R_1}{R_2}\right) V_{REF}$$

$V_{O\text{ MIN}} = V_{REF} + 5\text{ V}$

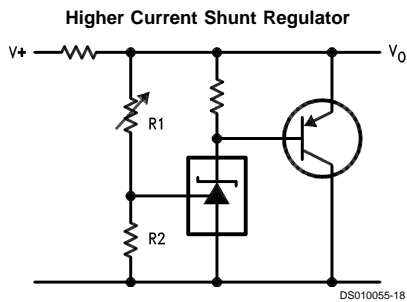

DS010055-18

$$V_O \approx \left(1 + \frac{R_1}{R_2}\right) V_{REF}$$

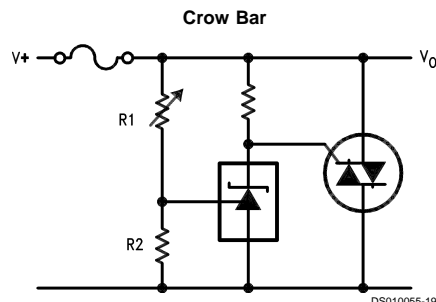

DS010055-19

$$V_{LIMIT} \approx \left(1 + \frac{R_1}{R_2}\right) V_{REF}$$

Typical Applications (Continued)

Over Voltage/Under Voltage Protection Circuit

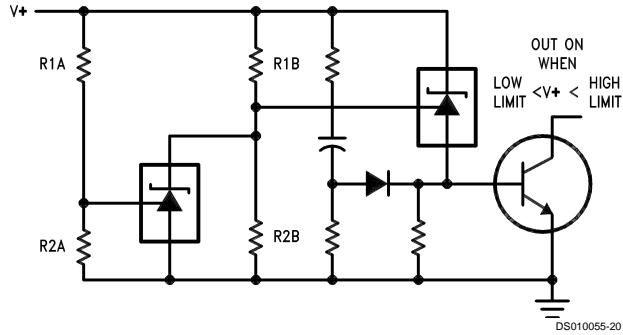

$$\text{LOW LIMIT} \approx V_{\text{REF}} \left( 1 + \frac{R1B}{R2B} \right) + V_{\text{BE}}$$

$$\text{HIGH LIMIT} \approx V_{\text{REF}} \left( 1 + \frac{R1A}{R2A} \right)$$

Voltage Monitor

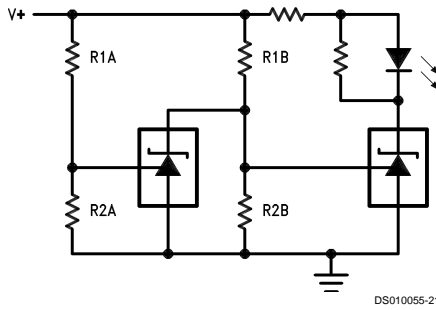

$$\text{LOW LIMIT} \approx V_{\text{REF}} \left( 1 + \frac{R1B}{R2B} \right) \quad \text{LED ON WHEN}$$

LOW LIMIT < V+ < HIGH LIMIT

$$\text{HIGH LIMIT} \approx V_{\text{REF}} \left( 1 + \frac{R1A}{R2A} \right)$$



## Typical Applications (Continued)

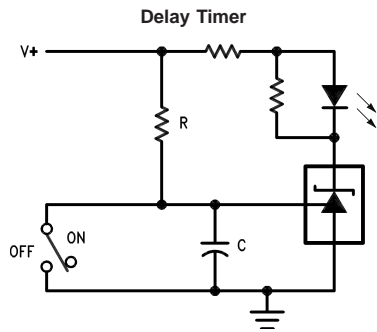

$$\text{DELAY} = R \cdot C \cdot \ln \frac{V+}{(V+) - V_{\text{REF}}}$$

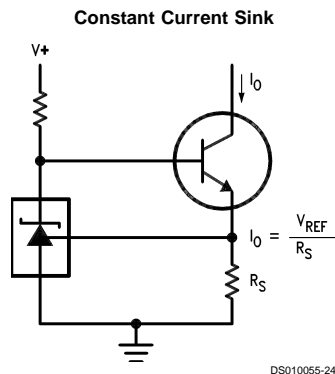
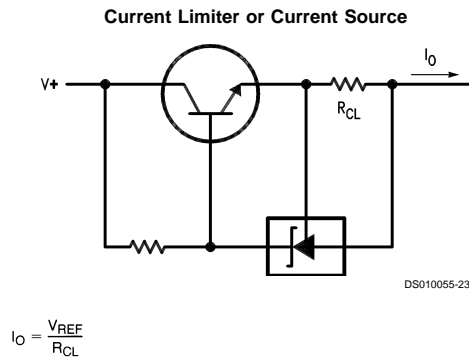

## Application Info

### 1.0 Mounting

To ensure that the geometry of the micro SMD package maintains good physical contact with the printed circuit board, pin 1 (NC) must be soldered to the pcb. Please see AN-1112 for more detailed information regarding board mounting techniques for the micro SMD package.

### 2.0 LM431 micro SMD Light Sensitivity

When the LM431 micro SMD package is exposed to bright sunlight, normal office fluorescent light, and other LED's and lasers, it operates within the guaranteed limits specified in the electrical characteristics table.

**Physical Dimensions** inches (millimeters) unless otherwise noted

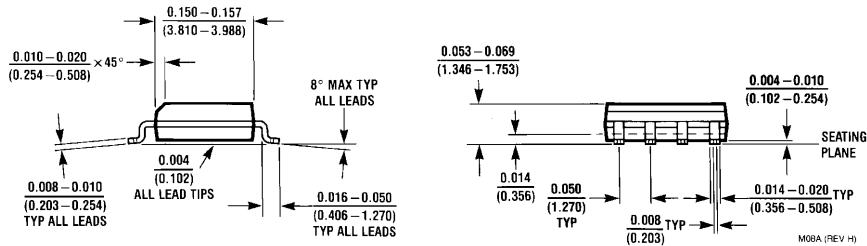
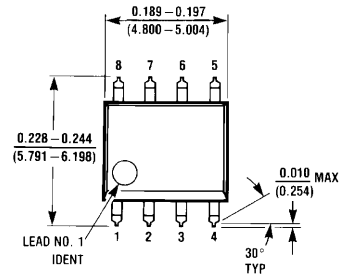

**NS Package Number M08A**

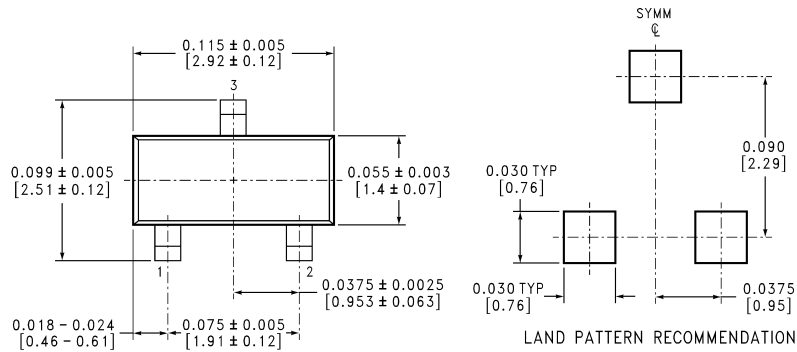

**LAND PATTERN RECOMMENDATION**

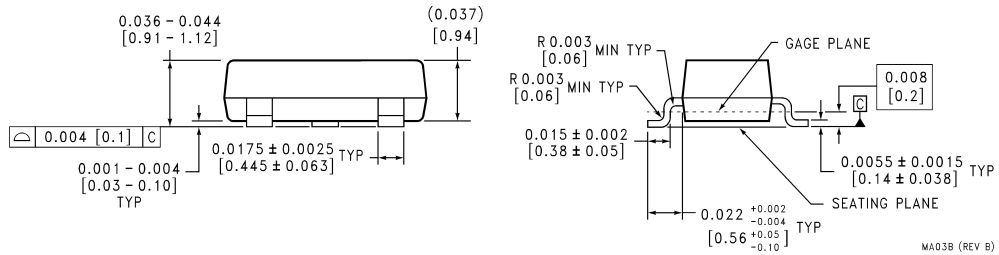

**SOT-23 Molded Small Outline Transistor Package (M3)  
NS Package Number MA03B**

**Physical Dimensions** inches (millimeters) unless otherwise noted (Continued)

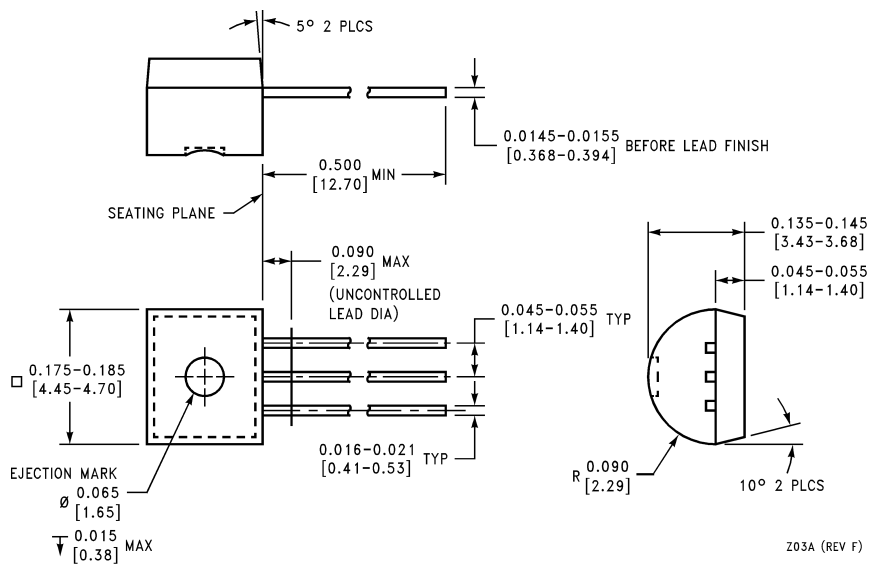

**NS Package Number Z03A**

**Physical Dimensions** inches (millimeters) unless otherwise noted (Continued)

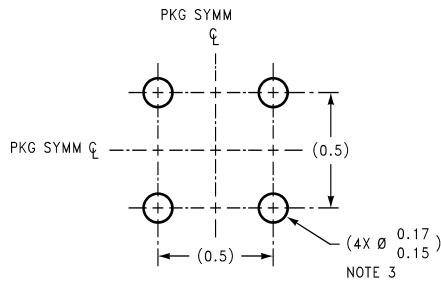
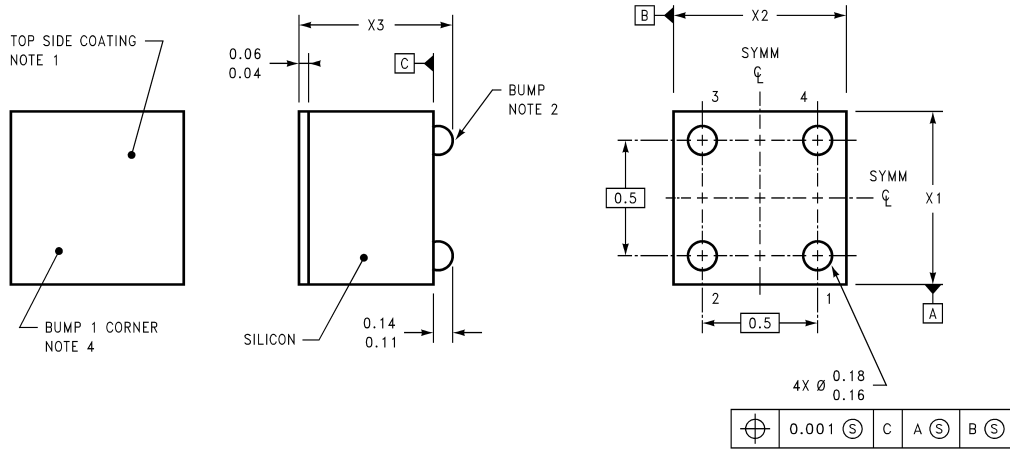

**DIMENSIONS ARE IN MILLIMETERS**

**LAND PATTERN RECOMMENDATION**

BPA04XXX (REV A)

NOTES: UNLESS OTHERWISE SPECIFIED

1. EPOXY COATING
2. 63Sn/37Pb EUTECTIC BUMP
3. RECOMMEND NON-SOLDER MASK DEFINED LANDING PAD.
4. PIN 1 IS ESTABLISHED BY LOWER LEFT CORNER WITH RESPECT TO TEXT ORIENTATION. REMAINING PINS ARE NUMBERED.
5. XXX IN DRAWING NUMBER REPRESENTS PACKAGE SIZE VARIATION WHERE X1 IS PACKAGE WIDTH, X2 IS PACKAGE LENGTH AND X3 IS PACKAGE HEIGHT.
6. REFERENCE JEDEC REGISTRATION MO-211, VARIATION BA.

**4-Bump micro SMD**  
**X1 = 0.780 X2 = 0.900 X3 = 0.700**  
**NS Package Number BPA04AFA**

## Notes

### LIFE SUPPORT POLICY

NATIONAL'S PRODUCTS ARE NOT AUTHORIZED FOR USE AS CRITICAL COMPONENTS IN LIFE SUPPORT DEVICES OR SYSTEMS WITHOUT THE EXPRESS WRITTEN APPROVAL OF THE PRESIDENT AND GENERAL COUNSEL OF NATIONAL SEMICONDUCTOR CORPORATION. As used herein:

1. Life support devices or systems are devices or systems which, (a) are intended for surgical implant into the body, or (b) support or sustain life, and whose failure to perform when properly used in accordance with instructions for use provided in the labeling, can be reasonably expected to result in a significant injury to the user.
2. A critical component is any component of a life support device or system whose failure to perform can be reasonably expected to cause the failure of the life support device or system, or to affect its safety or effectiveness.



**National Semiconductor Corporation**  
Americas  
Tel: 1-800-272-9959  
Fax: 1-800-737-7018  
Email: support@nsc.com

www.national.com

**National Semiconductor Europe**  
Fax: +49 (0) 1 80-530 85 86  
Email: europe.support@nsc.com  
Deutsch Tel: +49 (0) 1 80-530 85 85  
English Tel: +49 (0) 1 80-532 78 32  
Français Tel: +49 (0) 1 80-532 93 58  
Italiano Tel: +49 (0) 1 80-534 16 80

**National Semiconductor Asia Pacific Customer Response Group**  
Tel: 65-2544466  
Fax: 65-2504466  
Email: sea.support@nsc.com

**National Semiconductor Japan Ltd.**  
Tel: 81-3-5639-7560  
Fax: 81-3-5639-7507

This datasheet has been downloaded from:

[www.DatasheetCatalog.com](http://www.DatasheetCatalog.com)

Datasheets for electronic components.

# National Semiconductor was acquired by Texas Instruments.

[http://www.ti.com/corp/docs/investor\\_relations/pr\\_09\\_23\\_2011\\_national\\_semiconductor.html](http://www.ti.com/corp/docs/investor_relations/pr_09_23_2011_national_semiconductor.html)

This file is the datasheet for the following electronic components:

431CIM - <http://www.ti.com/product/431cim?HQS=TI-null-null-dscatalog-df-pf-null-wwe>

LM431ACM3N1F - <http://www.ti.com/product/lm431acm3n1f?HQS=TI-null-null-dscatalog-df-pf-null-wwe>

LM431AIM3N1E - <http://www.ti.com/product/lm431aim3n1e?HQS=TI-null-null-dscatalog-df-pf-null-wwe>

LM431BCM3N1D - <http://www.ti.com/product/lm431bcm3n1d?HQS=TI-null-null-dscatalog-df-pf-null-wwe>

431CCM - <http://www.ti.com/product/431ccm?HQS=TI-null-null-dscatalog-df-pf-null-wwe>

LM431BIM3N1C - <http://www.ti.com/product/lm431bim3n1c?HQS=TI-null-null-dscatalog-df-pf-null-wwe>

LM431CCM3N1B - <http://www.ti.com/product/lm431ccm3n1b?HQS=TI-null-null-dscatalog-df-pf-null-wwe>

LM431CIM3N1A - <http://www.ti.com/product/lm431cim3n1a?HQS=TI-null-null-dscatalog-df-pf-null-wwe>

431BIM - <http://www.ti.com/product/431bim?HQS=TI-null-null-dscatalog-df-pf-null-wwe>

431BCM - <http://www.ti.com/product/431bcm?HQS=TI-null-null-dscatalog-df-pf-null-wwe>