

General Description

The QXpander QX2010 is a bipolar analog stereo enhancement processor. This device is part of the QX chip family offered by QSound Labs, and uses the patented QXpander™ technology to produce a spatially widened stereo image from ordinary left and right channel inputs.

This audio enhancement is achieved while using normal stereo signals and standard stereo audio equipment. No special initial encoding of the input signals is required, no additional speakers are required, and no special hardware is needed to produce QXpanded audio.

A TTL-compatible control input is provided to select QXpanded audio or a normal stereo signal (bypass). The QX2010 is fabricated in bipolar technology, and is offered in a 22 pin SDIP standard package. A 20 pin plastic SSOP package is available on request.

Features

- Produce a wide sound image from normal stereo input.
- No encoding of input signals, no special equipment required to QXpand audio.
- TTL-compatible bypass control.
- Low noise: 55 uV_{RMS}.
- High signal-to-noise ratio: 85 dB.
- single supply voltage.
- Few external components, low cost.

Applications

- Television sound systems (Stereo).
- Semi-professional audio equipment.
- Personal/portable audio.
- Multimedia applications for PCs and laptops.
- Multimedia speaker systems.
- Video Games.

Pin Assignment

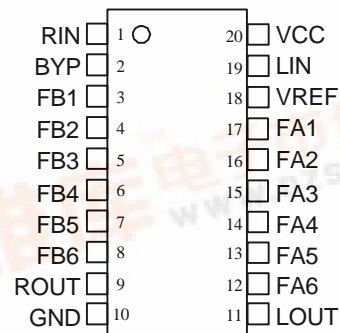

Figure 1: SSOP pinout

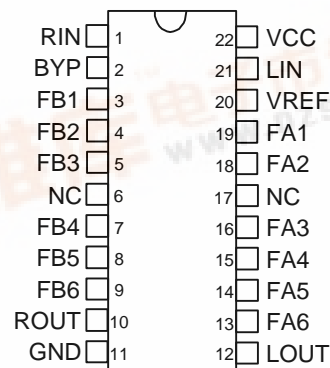

Figure 2: SDIP Pin Assignment



Principles of Operation.

In ordinary stereo systems, the stereo image is formed between the left and right speakers, and is confined by the speaker positions (i.e., the "sound stage" is located between the two speakers). The QXpander™ is designed to form the stereo image beyond the speakers, thus enlarging the "sound stage".

If the center channel is defined as the monaural or common component of the left and right channels, then Figure 3 shows the spatial response of the QXpander™ when operating, and for normal stereo bypass.

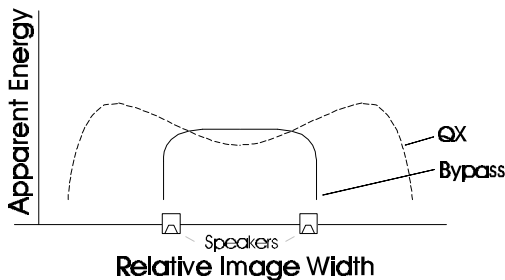

Figure 3: QXpander™ Spatial Response

The QXpander™ enhancements can be disabled using the BYP bypass control pin, allowing the unchanged stereo signal to pass through to the outputs. The BYP control pin requires V_{CC} and 0 VDC as logic levels 1 and 0 respectively (see Table 1).

BYP		MODE
0	(GND)	Bypass - Normal Stereo
1	(2.4 ~ V _{CC})	QXpanded Audio

Table 1: Mode Selection

Normally, the QXpander™ is used in the preamplifier stage between the stereo source and the amplifier stages used to drive the speakers. Figure 4 shows the functional elements of the QX2010.

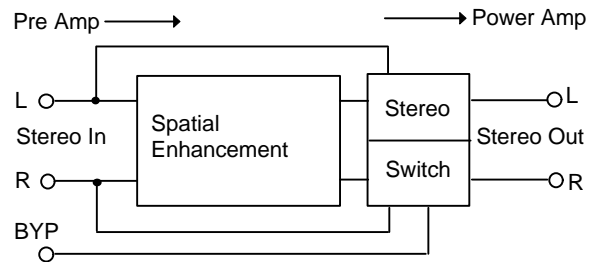

Figure 4: QXpander™ Simplified Block Diagram

QSound applications engineers can assist customers in integrating the QX2010 into their application designs.

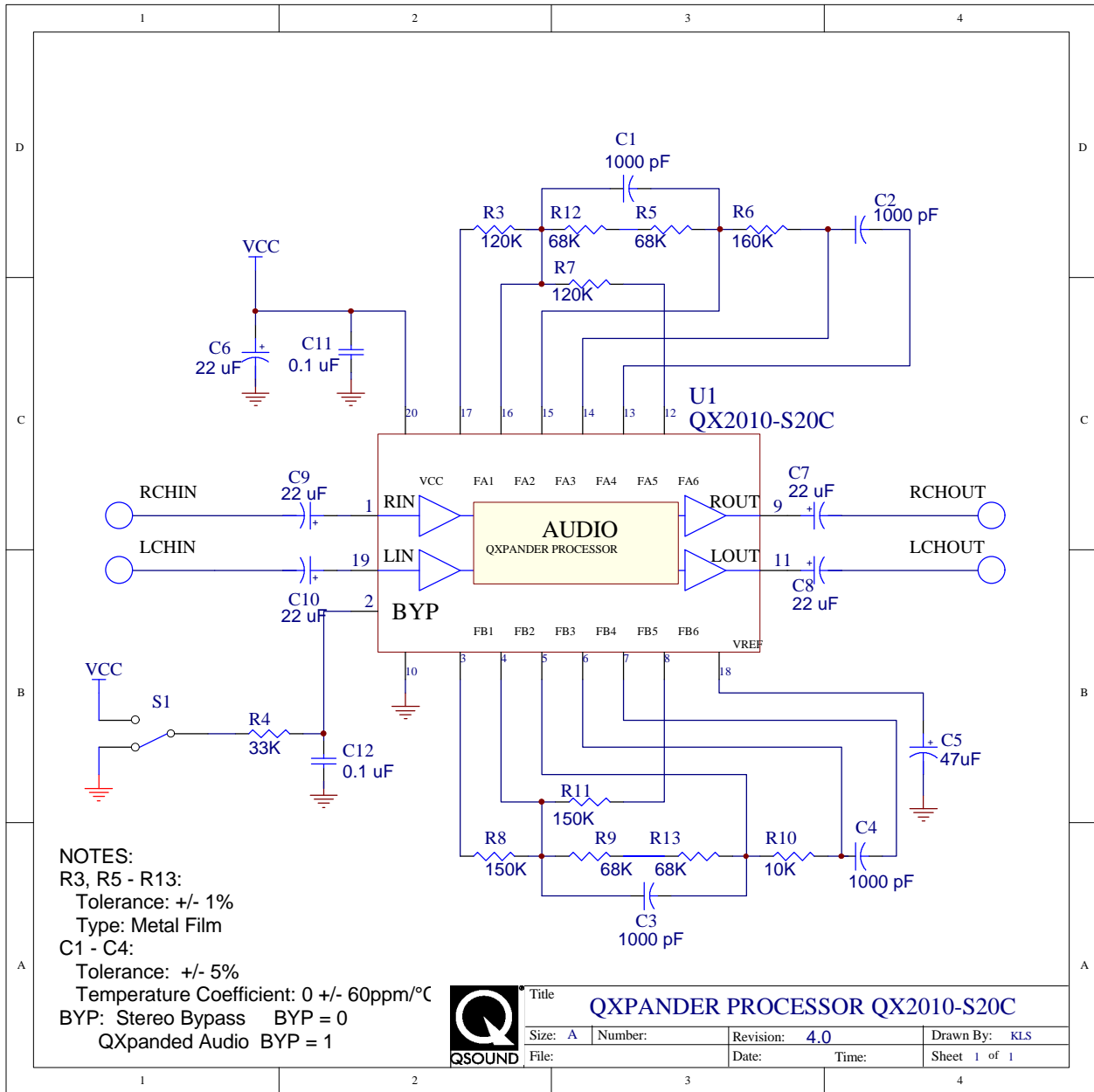

Figure 5: QX2010 QXpander™ Typical Application

Absolute Maximum Ratings*(T_A = +25 °C)

Parameter	Symbol	Rating	Unit
Supply Voltage	V _{CC,max}	12	V
Input Voltage	V _{IN,max}	GND ≤ V _{IN} ≤ V _{CC}	V
Output Current	I _{C,max}	10	mA
Power dissipation	P _d	500	mW
Operating Temperature	T _{opr}	-20 ~ +75	°C
Storage Temperature	T _{stg}	-40 ~ +125	°C

Warning: Operation of the device at or beyond these limits may result in permanent damage to the device. Normal operation is not guaranteed at these extremes.

Digital Characteristics(T_A = +25 °C, V_{CC} = 6.0 ~ 10.0 VDC)

Parameter	TC	Sym	Min	Typ	Max	Unit
High-Level Input Voltage		V _{IH}	2.5		5.0	V
Low-Level Input Voltage		V _{IL}	0	0.4	0.8	V
High-Level Input Current		I _{IH}			TBD	uA
Low-Level Input Current		I _{IL}			TBD	uA

Note: Digital input (BYP, pin 2) should be driven with levels between 0V ~ +5V relative to GND.

Analog Characteristics:(T_A = +25 °C, V_{CC} = 9.0 VDC)

Parameter	TC	Sym	Min	Typ	Max	Unit
Supply Voltage Range		V _{CC}	6.0	9.0	10.0	VDC
Power Supply Rejection Ratio	1	PSRR	44	50		dB
Supply Current		I _{CC}		15	20	mA
Input Voltage, Analog	2	V _{in}		1.0	1.4	V _{RMS}
Output Voltage, Analog	3	V _{OUT}	2.0	2.8		V _{RMS}
Output Current, Analog		I _{OUT}			±1	mA
Load Resistance		R _L	5			kΩ
Load Capacitance		C _L			100	pF
Input Impedance		R _I	21	30	39	kΩ
Usable Bandwidth		BW	20		20000	Hz
Voltage Gain, QXpanded	4	A _{V,1}	5.0	6.0	7.0	dB
Voltage Gain, bypass	5	A _{V,2}	-0.5	0.0	+0.5	dB
Total Harmonic Distortion	6	THD		0.3	0.7	%
Signal-Noise Ratio, QXpander	7	SNR	80	85		dB
Signal-Noise Ratio, Bypass	8	SNR	90	95		dB
Output Noise Voltage	9	V _{NOISE}		55	100	μV _{RMS}
Channel Balance	10	CB	-1.0		+1.0	dB
Insertion Loss					0.5	dB

Test Conditions:

- V_{CC} = 9V + 200 mV_{RMS}, f = 1 kHz, BYP = V_{CC} (QXpanded mode).
- V_{CC} = 9.0 V, BYP = V_{CC} (QXpanded mode).
- BYP = V_{CC} (QXpanded mode), THD = 1%, f = 1 kHz.
- BYP = V_{CC} (QXpanded mode),
 - LIN = 1 V_{RMS}, 1 kHz, RIN=0 V,
 - RIN= 1 V_{RMS}, 1 kHz, LIN=0 V.
- BYP = GND (Bypass mode), LIN = RIN = 1 V_{RMS}, 1 kHz.
- Total Harmonic Distortion:
 - THD at LOUT: LIN = 1 V_{RMS}, RIN = 0 V, 1 kHz, BYP = V_{CC} (QXpanded mode).
 - THD at ROUT: RIN = 1 V_{RMS}, LIN = 0 V, 1 kHz, BYP = V_{CC} (QXpanded mode).
- BW = 20 ~ 20000 Hz, LOUT = ROUT = 1 V_{RMS}, BYP = V_{CC}, A curve.(QXpanded mode).
- BW = 20 ~ 20000 Hz, LIN = RIN = 1 V_{RMS}, BYP = GND, A curve. (Bypass mode).
- BW = 20 ~ 20000 Hz, BYP = V_{CC}, A curve. (QXpanded mode).
- LIN = RIN = 1 V_{RMS}, 1 kHz, BYP = GND (Bypass mode).

Bill of Material

For low cost implementation

Item	Quantity	Description	Reference
1	1	10 k Ω , 1/4W, 5%, Carbon Film Resistor	R10
2	1	33 k Ω , 1/4W, 5%, Carbon Film Resistor	R4
3	2	120 k Ω , 1/4W, 5%, Carbon Film Resistor	R3, R7
4	2	130 k Ω , 1/4W, 5%, Carbon Film Resistor	R9 or R13, R5 or R12
5	2	150 k Ω , 1/4W, 5%, Carbon Film Resistor	R8, R11
6	1	160 k Ω , 1/4W, 5%, Carbon Film Resistor	R6
7	4	0.001 uF, 5%, 50V, Ceramic Disk Capacitor	C1, C2, C3, C4
8	2	0.1uF, 50V, 10% Capacitor	C11, C12
9	5	22.0uF, 16V Electrolytic Capacitor	C6, C7, C8, C9, C10
10	1	47.0uF, 16V Electrolytic Capacitor	C5
11	1	QX2130SDIP Integrated Circuit	U1

NOTE: These values are suitable for applications where cost is an overriding factor. Operation within quoted specifications cannot be guaranteed using the parts listed above. When strict conformance to the quoted specifications is required use the values indicated on the schematic.

Package Data

Ordering Code	Package Code	Package Type
QX2010-P22C	P22	PLASTIC SDIP
QX2010-S20C	S20	PLASTIC SSOP

